



## Q4 1 & 1/2 BOWL RADIAL CORNER SINK FLATBED DRAINER & ACCESSORY PACK 1

### DESCRIPTION

Q4 1 & 1/2 Bowl Radial Corner Sink with Flatbed Drainer and Accessory Pack 1

### FEATURES

- 15mm radial corner
- In-built drainer
- Fine lustre finish
- 1.2mm 304 stainless steel
- Turn down edge
- Underside coated with an anti-condensation layer and sound deadening rubber pads all sides
- Tilo designed continuous bracketing system for rigidity and secure topmounting
- Includes sink, dish rack, chopping board, standard lift-up plug & waste, sealing rubber, set of undermount and topmount clips
- 25 year limited domestic manufacturer's warranty on sinks only from date of purchase
- 1 year manufacturer's warranty on sink accessories except chopping boards from date of purchase

### DETAILS

30 / 16L Capacity

Undermount or topmount

Part Code: TKS-210RA

Available Finishes: Brushed on sink, chromed on dish rack

### TECHNICAL DETAILS

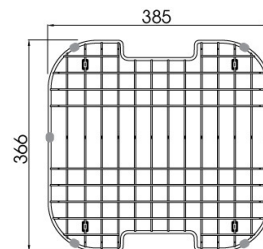
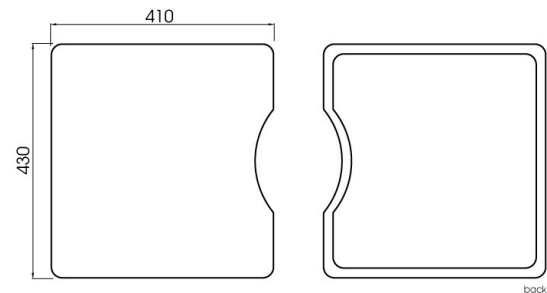
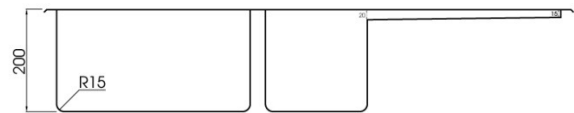
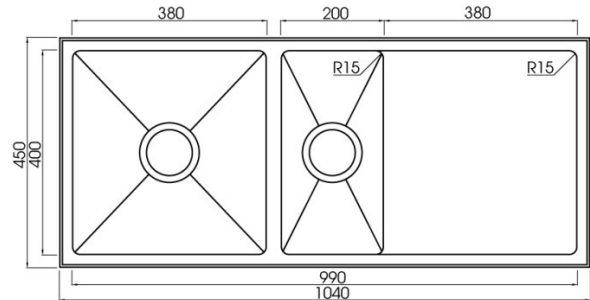

Note: Illustrations and specifications may vary from time to time